

The EBELCO 600 series electromagnetic locks are renowned with its excellent holding force and the remarkable features.

The series compliance to CE and PSB Test are manufactured under the highest quality control to achieve the commitment to customer who always satisfied with maximum quality and reliability.

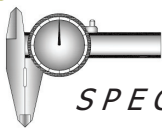

SPECIFICATIONS:

- ▶ Voltage Input : 12 VDC / 24 VDC
- ▶ Current Draw : 12V / 500mA ; 24V / 250mA (±5%)
- ▶ Holding Force : Up to 600 lbs (272 kg)
- ▶ Hall Effect Contact : SPDT rated 2A at 24 VDC
- ▶ Anti-Rust Surface Treatment : Blue Zinc Plating
- ▶ Operating Temperature : 0~55° C (32~131° F)
- ▶ Operating Humidity : 0~95% (non condensing)
- ▶ Weight (Magnet) : 1.1 kg (±1%)
- ▶ Dimensions : Magnet - (L)250x(W)42x(T)25 mm
Armature - (L)180x(W)38x(T)11 mm



FEATURES:

- ▶ Dual Voltage Selectable (12 VDC or 24 VDC)
- ▶ Selectable Re-locking Timer 5,10,15,25 Sec
- ▶ Built-in EXIT Push Switch
- ▶ Door Open Time Buzzer Monitoring
- ▶ Reliable Holding Force
- ▶ Hall Effect Sensor Monitoring Output
- ▶ Green/Red LED Indication for EM Lock Status
- ▶ Durable and Silence Operation
- ▶ Surge & Spike Protection PCB
- ▶ Anti-Tamper Jam Nuts
- ▶ Full Range of Optional Brackets
- ▶ Anti Residual Magnetism Kick Off Button

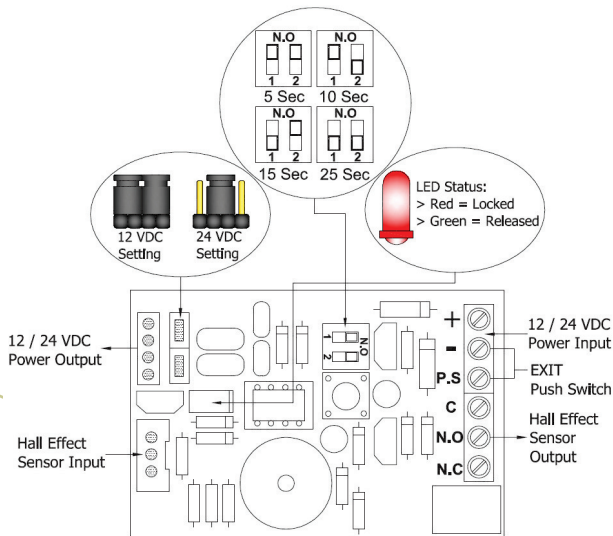

IMPORTANT!

Set the jumper position according to the power input correctly before switch ON the power.

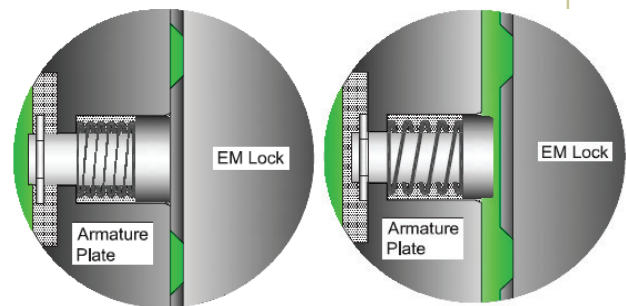

Disclaimer :

EBELCO reserve the right to go ahead with any modifications of models or features or price without forewarning. All the information and specifications stated in this document are current at the time of publication.

Security . Quality . Reliability